

MODELLO

VITE A RICIRCOLAZIONE DI SFERE DI PRECISIONE A PIU' PRINCIPI TAB.4

MOD.

HIGH - SPEED MULTIPLE STARS PRECISION BALLSCREWS

TAB.4

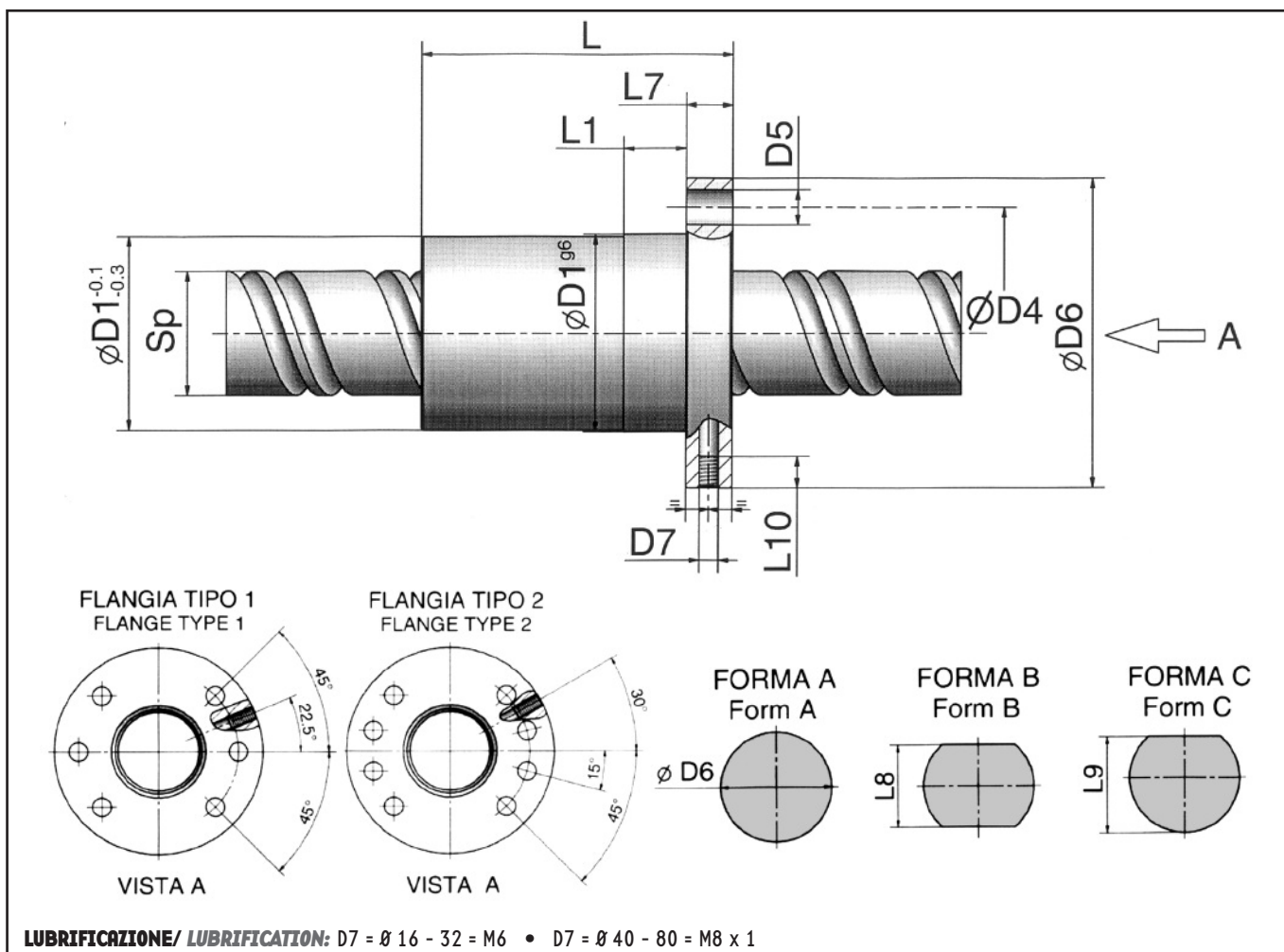

PRESTAZIONI

Alto valore DmN:
 130.000 in casi normali. In alcune applicazioni speciali e' possibile ottenere, previa verifica del ns.uff.tecnico, un valore di 140.000.

Elevata Velocita' lineare:
 Grazie al sistema di ricircolo interno (brevettato) ed alla speciale conformita' del profilo e' possibile raggiungere velocita' di 100 m/min.

Elevata Rigidita' e capacita' di carico:
 l'aumento delle sfere dato dall'esecuzione di 2 principi permette il notevole incremento del carico dinamico e della rigidita' complessiva della vite.

PERFORMANCES

High DmN value:
 130'000 in normal cases. In some special applications a value of 140'000 can be obtained. However, a verification must be done by our Technical Dept.

High linear speed:
 Due to the internal recirculation system (patented) and to the special conformation of the profile, a speed up to 100 m/min can be obtained.

High stiffness and loading capacity:
 The increase of the number of balls thanks to the double-thread design permits a considerable increase of the dynamic load and of the total stiffness of the ballscrew.



Tipo/ Size		Circuiti/ Effect. turns i	Capacità di carico/ Basic Rate Load		Rigidità/ Stiffness	Dimens.chiocciola / Nut dimensions										Sfera Ball mm	Sp(h6) mm							
d0 mm	Ph mm		Cdyn (KN)	Cstat (KN)		Rb/t KN/um	L mm	D1g6 mm	D4 mm	D5 mm	D6 mm	D7 mm	L1 mm	L7 mm	L8 mm			L9 mm	L10 mm					
20	20	2 x 2	11,290	19,000	10,96	64	36	47	6,6	58	M6 (Flangia Tipo -Type1)	10	10	44	51	5	3,175	20						
	25	2 x 1	5,580	8,280	5,36	85						10	10	48	55	5			3,175					
	25	2 x 2	10,880	18,470	10,62	85						10	10	48	55				3,175					
25	20	2 x 2	12,000	23,280	11,26	70	40	51	6,6	62		10	10	48	55	5	4,500	24						
	20	2 x 2	21,070	33,050	15,38	85	50	65	9	80		16	14	62	71				3,175					
	25	2 x 2	11,700	22,830	11,02	80	40	51	6,6	62		10	10	48	55				3,175					
	25	2 x 2	20,560	32,440	15,06	95	50	65	9	80		16	14	62	71				4,500					
	32	2 x 1	5,720	9,880	5,34	105	40	51	6,6	62		10	10	48	55				5	3,175				
	32	2 x 2	11,180	22,040	10,60	105																		
	32	2 x 1	10,080	14,060	7,32	110	50	65	9	80		16	14	62	71				5	4,500				
	32	2 x 2	19,670	31,360	14,51	110																		
32	20	2 x 2	22,240	42,040	15,70	95	50	65	9	80		16	14	62	71	6	4,500	30						
	20	2 x 3	39,290	58,970	21,49	95	56	70	9	85									14	63	74	6,350		
	32	2 x 2	21,290	40,650	15,13	120	50	65	9	80									14	62	71	4,500		
	32	2 x 2	37,660	57,070	20,73	120	56	70	9	85									14	63	74	6,350		
	40	2 x 1	10,460	17,650	7,36	130	50	65	9	80	14								62	71	6	4,500		
	40	2 x 2	20,420	39,370	14,60	130																		
	40	2 x 1	18,530	24,800	10,10	135	56	70	9	85	16								63	74	6	6,350		
	40	2 x 2	36,180	55,340	20,04	135																		
40	20	2 x 3	59,310	117,540	32,24	95	63	78	9	93	16	14	70	81,5	7	6,350	38							
	40	2 x 2	38,880	72,790	20,81	135												20	85	97,5	9,520			
	40	2 x 2	39,810	48,110	15,36	135	63	78	9	93								14	70	81,5	7	6,350		
	50	2 x 1	19,130	31,640	10,14	160																		
	50	2 x 2	37,340	70,590	20,12	160	75	93	11	110								20	85	97,5	7	9,520		
	50	2 x 1	38,300	46,700	14,87	160																		
50	2 x 2	74,770	104,170	29,50	160																			
50	20	2 x 3	62,830	149,900	32,83	110	75	93	11	110	16	16	85	97,5	8	6,350	48							
	40	2 x 2	41,953	94,204	21,53	140												22	95	110	9,520			
	40	2 x 2	80,620	139,390	30,93	145	90	108	11	125								16	16	85	97,5	8	6,350	
	60	2 x 1	20,320	40,450	10,35	180																		
	60	2 x 2	39,677	90,248	20,54	180	90	108	11	125								22	95	110	8	9,520		
	60	2 x 1	39,110	59,920	14,89	185																		
60	2 x 2	76,350	133,670	29,53	185																			
63	40	2 x 2	45,510	119,580	22,25	140	90	108	11	125	16	16	18	95	110	9	6,350	60						
	40	2 x 2	84,680	177,430	31,49	145	105	125	13,5	145									16	25	110	127,5	9,520	
	50	2 x 2	44,780	118,120	21,95	160	90	108	11	125									16	18	95	110	6,350	
	50	2 x 2	83,360	175,300	31,08	165	105	125	13,5	145									16	25	110	127,5	9,520	
	80	2 x 1	21,370	50,140	10,42	220	90	108	11	125									16	18	95	110	9	6,350
	80	2 x 2	41,720	111,870	20,67	220																		
	80	2 x 1	39,840	74,490	14,77	225	105	125	13,5	145									16	25	110	127,5	9	9,52
	80	2 x 2	77,77	166,180	29,31	225																		
80	40	2 x 2	92,000	240,260	32,43	145	125	145	13,5	165	25	25	130	147,5	10	9,520	80							
	60	2 x 2	90,200	236,620	31,89	185																		
	80	2 x 2	87,700	231,560	31,14	225																		

- A richiesta:
- Chiocciola in versione rotante
- Raschiatori in materiale plastico autolubrificante
- Versione precaricata (max 5% Cdyn)
- Versione con gioco assiale ridotto

- On request:
- Rotating nut
- Wipers made of special selflubricating PTFE material
- Preloaded type (max 5% Cdyn)
- Version with reduced axial play

- Principi: 2
- Classi di precisione 3-5-7 secondo norme ISO/TC39/WG7 179
- Elica destrorsa standard

- Number of starting: 2
- Accuracy classes 3-5-7 according to ISO/TC 39/WG7 179
- R.H. thread as standard